

## T042TF830ELPW | CCTLED DOWNLIGHT Tech

### Recessed LED downlight

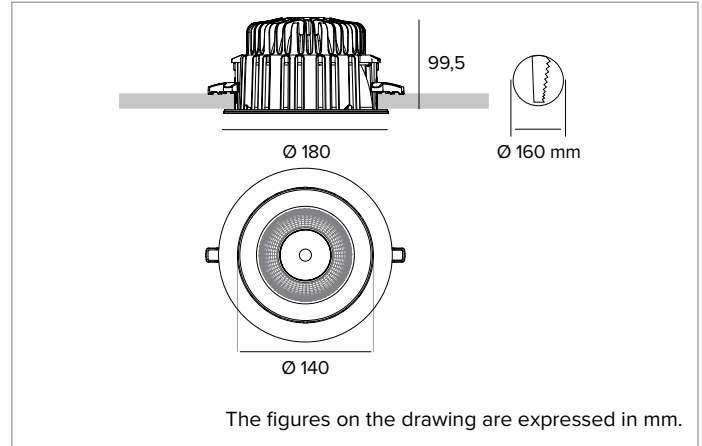

	3000K	H(m)	D(m)	E <sub>max</sub> (lx)
	Ra80		70°	
Fixture Power	20W	1	1.40	1981
Source Flux	3168lm	2	2.81	495
Fixture Flux	2588lm	3	4.21	220
Efficacy	131lm/W	4	5.61	124
TS1701	I <sub>max</sub> =702cd/klm	I <sub>max</sub>	2225cd	5
			7.02	79



#### SOURCE

High efficiency Chip on Board LED Ra80.

**Energy efficiency class:** D

**Nominal power:** 17W

**Nominal flux:** 3168lm

**Colour rendering index:** 80

**Rf:** 84

**Rg:** 96

**CCT nominal:** 3000K

**Lifetime (L80/B10):** >100000h tq +25°C

#### ILLUMINOTECHNICAL CHARACTERISTICS

The optical system consists of a double reflector: the primary reflector is low luminance and faceted with a high reflectance mirror finish and diffusing matt outer treatment; the secondary reflector has a mirror finish. Micro prismatic polycarbonate refractor. The fixture is suitable for installation in workplaces, in compliance with European standard EN-12464 (UGR<19).

**Optic:** SECONDARY FACETTED

**Beam angles:** WFL

**Optical efficiency:** 82%

**Fixture flux:** 2588lm

**Luminous efficacy:** 131lm/W

**Photobiological safety:** Compliant with RG1 low risk group

#### MECHANICAL CHARACTERISTICS

Body and heat sink in die-cast anodised aluminium. Passive heat sink cooling system. Completed with decorative white rounded ring.

**Colour and finish:** White

**Weight:** 0.9Kg

**Degree of protection:** IP20 for recessed part

**Degree of protection:** IP43 for exposed part

#### ELECTRICAL CHARACTERISTICS

Complete with an electronic ON/OFF driver. Emergency kit with 1h and 3h batteries available as accessories. Luminaire compliant with EN 60598-2-22 for power supply from a centralised emergency system CPSS (Central Power Supply System), not incorporated in the luminaire - high risk areas excluded. The default power and flux are 100% in AC and 100% in DC.

**Fixture Power:** 20W

**Power supply:** 220-240Vac 50/60Hz

**Insulation Class:** CLASS 2

**Type of driver / Control:** ON-OFF

**Driver included:** YES

**Class F:** YES

**SAFE FLICKER:** PstLM=<1 and SVM=<0.4 (IEC TR 61547-1 and IEC TR 63158), to ensure a more comfortable and safe light

**Ambient temperature:** 0°C / +25°C

#### INSTALLATION

Quick tool-free mounting system for false ceiling installation from 0.5 to 30mm.

#### NOTES

110-277Vac version available on request.

#### WARRANTY

5 years.

#### WARNING

Luminaire designed for disposal/recycling at end-of-life. Replaceable (LED only) light source by a professional. Replaceable control gear by a professional.

*Due to the technological evolution of the electronic components, the data provided may be updated, and as such, confirmation must be requested during the order process.*

*Luminous flux and power supply have +/-10% tolerances with respect to the indicated value. tq +25°C (CIE 121).*

*We reserve the right to make technical changes.*

Targetti Sankey S.r.l.  
Via Pratese, 164  
50145 Firenze - Italy  
Tel: +39 055 37911  
targetti.com  
targetti@targetti.com

CCIAA Firenze  
Share Capital:  
€ 500.000,00  
VAT N. (IT):  
01537660480  
R.E.A: FI-275656

**TARGETTI**

## T042TF830ELPW | CCTLED DOWNLIGHT Tech

### Recessed LED downlight

## Accessories

### Emergency Kit



Code

**A059**

Emergency kit composed of an inverter a LiFePO4 battery and a LED Green indicator. Allows permanent EP emergency use of the fixture it is connected to.

The 1h or 3h autonomy can be selected by configuring the fixture.

The batteries take 12h to completely recharge.

LED Green indicator wired to the inverter through single-core cables L= 800mm.

Emergency kit for fixtures that comply with EN 60598-2-22 standard, high risk areas excluded.

Battery size 160x54x30 mm.

Inverter size 165x40x25 mm.

*Due to the technological evolution of the electronic components, the data provided may be updated, and as such, confirmation must be requested during the order process.*

*Luminous flux and power supply have +/-10% tolerances with respect to the indicated value. tq +25°C (CIE 121).*

*We reserve the right to make technical changes.*

Targetti Sankey S.r.l.  
Via Pratese, 164  
50145 Firenze - Italy  
Tel: +39 055 37911  
targetti.com  
targetti@targetti.com

CCIAA Firenze  
Share Capital:  
€ 500.000,00  
VAT N. (IT):  
01537660480  
R.E.A: FI-275656

# TARGETTI